

Operator: Save these instructions for future use!

FAILURE TO READ AND FOLLOW ALL INSTRUCTIONS CAREFULLY BEFORE INSTALLING OR OPERATING THIS CONTROL COULD CAUSE PERSONAL INJURY AND/OR PROPERTY DAMAGE.

DESCRIPTION

The 50A66-743 is an automatic gas interrupted ignition control that employs a microprocessor to continually monitor, analyze, and control the proper operation of the gas burner, inducer, and fan.

Signals interpreted during continual surveillance of the thermostat and flame sensing element initiate automatic ignition of the burner, sensing of the flame, and system shut-off during normal operation.

These controls incorporate system fault analysis for quick gas flow shut-off, coupled with automatic ignition retry upon sensing a fault correction.

50A66-743 Cross Reference Information

Lennox			White-Rodgers
100925-01	23W51	69M0801	50A66-122
100925-02	23W5101	69M15	50A66-123
100925-03	30W25	69M1501	50A66-743
17W92	30W2501		
17W9201	69M08		

PRECAUTIONS

Installation should be done by a qualified heating and air conditioning contractor or licensed electrician.

If in doubt about whether your wiring is millivolt, line, or low voltage, have it inspected by a qualified heating and air conditioning contractor or licensed electrician.

Do not exceed the specification ratings.

All wiring must conform to local and national electrical codes and ordinances.

This control is a precision instrument, and should be handled carefully. Rough handling or distorting components could cause the control to malfunction.

Following installation or replacement, follow manufacturer's recommended installation/service instructions to ensure proper operation.

CAUTION

Do not short out terminals on gas valve or primary control. Short or incorrect wiring may damage the thermostat.

CONTENTS

Description	1
Precautions	1
Specifications	2
Installation	3
Mounting & Wiring	
Operation	6
System Lockout and Diagnostic Features	7
Troubleshooting	8

WARNING



Failure to comply with the following warnings could result in personal injury or property damage.

FIRE HAZARD

- Do not exceed the specified voltage.
- Replace existing control with exact model and dash number.
- Protect the control from direct contact with water (dripping, spraying, rain, etc.).
- If the control has been in direct contact with water, replace the control.
- Label all wires before disconnection when servicing controls. Wiring errors can cause improper and dangerous operation.
- Route and secure wiring away from flame.

SHOCK HAZARD

- Disconnect electric power before servicing.
- Ensure proper earth grounding of appliance.
- Ensure proper connection of line neutral and line hot wires.

EXPLOSION HAZARD

- Shut off main gas to appliance until installation is complete.

SPECIFICATIONS

ELECTRICAL RATINGS [@ 77°F (25°C)]:

Input Voltage: 25 VAC 50/60 Hz

Max. Input Current @ 25 VAC: 0.45 amp

Relay Load Ratings:

Valve Relay: 1.5 amp @ 25 VAC 50/60 Hz 0.6 pf

Ignitor Relay: 2.0 amp @ 120 VAC 50/60 Hz
(resistive)

Inducer Relay: 2.2 FLA–3.5 LRA @ 120 VAC

Circulator Relay: 14.5 FLA–25.0 LRA @ 120 VAC

Flame Current Requirements:

Minimum current to insure flame detection: 0.25 µA DC*

Maximum current for non-detection: 0.1 µA DC*

Maximum allowable leakage resistance: 100 M ohms

*Measured with a DC microammeter in the flame probe lead

OPERATING TEMPERATURE RANGE:

-40° to 175°F (-40° to 80°C)

HUMIDITY RANGE:

5% to 93% relative humidity (non-condensing)

MOUNTING:

Surface mount multipoise

Timing Specs: (@ 60 Hz**)

	maximum
Flame Establishing Time:	0.8 sec
Flame Failure Response Time:	2.0 sec

** At 50 Hz, all timing specifications should be increased by 20%

Gases Approved: Natural, Manufactured, Mixed, Liquefied Petroleum, and LP Gas Air Mixtures are all approved for use.

TIMING SPECIFICATIONS (All times are in seconds, unless noted otherwise)

Event	Definition	50A66-743
Pre-Purge	The period of time intended to allow for the dissipation of any unburned gas or residual products of combustion at the beginning of a furnace operating cycle prior to initiating ignition	15
Trial for Ignition Period (TFI)	The period of time between initiation of gas flow and the action to shut off the gas flow in the event of failure to establish proof of the supervised ignition source or the supervised main burner flame.	4
Ignition Activation Period (IAP)	The period of time between energizing the main gas valve and deactivation of the ignition means prior to the end of TFI	4
Retries	The additional attempts within the same thermostat cycle for ignition when the supervised main burner flame is not proven within the first trial for ignition period.	4 times
Valve Sequence Period	Valve sequence period equals 4 seconds trial for ignition period x (1 initial try + 2 retries) + 12 seconds.	20
Interpurge	The period of time intended to allow for the dissipation of any unburned gas or residual products of combustion between the failed trial for ignition and the retry period.	15
Post-Purge	The period of time intended to allow for the dissipation of any unburned gas or residual products of combustion at the end of a furnace burner operating cycle. Post-purge begins at the loss of flame sense.	5
Lockout Time	ANSI standard rated module timing.	250
Heat Delay-To-Fan-On	The period of time between proof of the supervised main burner flame and the activation of the blower motor at Heat speed.	45
Heat Delay-To-Fan-Off*	The period of time between the loss of a call for heat and the deactivation of the blower motor at Heat speed.	60/90/120/180
Cool Delay-To-Fan-On	The period of time after a thermostat demand for cool before energizing the circulator blower motor at Cool speed.	2
Cool Delay-To-Fan-Off*	The period of time between the loss of a call for cool and the deactivation of the blower motor at Cool speed.	2/45
Ignitor Warm-up	The length of time allowed for the igniter to heat up prior to the initiation of gas flow.	20
Auto Reset	After one (1) hour of internal or external lockout, the control will automatically reset itself and go into an auto restart purge for 60 seconds.	60 minutes
Humidifier		Yes
Electronic Air Cleaner		Yes

*This time will vary depending on option switch position. The control is factory set at 90 seconds HEAT delay-to-fan-off and 45 seconds COOL delay-to-fan-off. See OPERATION section for further information.

! WARNING



FIRE HAZARD

- Do not exceed the specified voltage.
- Replace existing control with exact model and dash number.
- Protect the control from direct contact with water (dripping, spraying, rain, etc.).
- Label all wires before disconnection when servicing controls. Wiring errors can cause improper and dangerous operation.
- Route and secure wiring away from flame.

SHOCK HAZARD

- Disconnect electric power before servicing .
- Ensure proper earth grounding of appliance.
- Ensure proper connection of line neutral and line hot wires.

EXPLOSION HAZARD

- Shut off main gas to appliance until installation is complete.

CAUTION

Do not short out terminals on gas valve or primary control. Short or incorrect wiring may damage the thermostat.

MOUNTING AND WIRING

All wiring should be installed according to local and national electrical codes and ordinances.

The control must be secured to an area that will experience a minimum of vibration and remain below the maximum ambient temperature rating of 175°F. The control is approved for minimum ambient temperatures of -40°F.

Any orientation is acceptable.

Refer to the wiring diagram and wiring table when connecting the 50A66 control to other components of the system.

UL approved, 105°C rated 18 gauge, stranded, 2/64" thick insulation wire is recommended for all low voltage safety circuit connections. Refer to 50A66 specification sheet for recommended terminals to mate with those on the control.

UL approved 105°C rated 16 gauge min., stranded, 4/64" thick insulation wire is recommended for all line voltage connections. Refer to 50A66 specification sheet for recommended terminals to mate with those on the control.

After installation or replacement, follow appliance manufacturer's recommended installation or service instructions to ensure proper operation.

WIRING

TYPICAL SYSTEM WIRING DIAGRAM

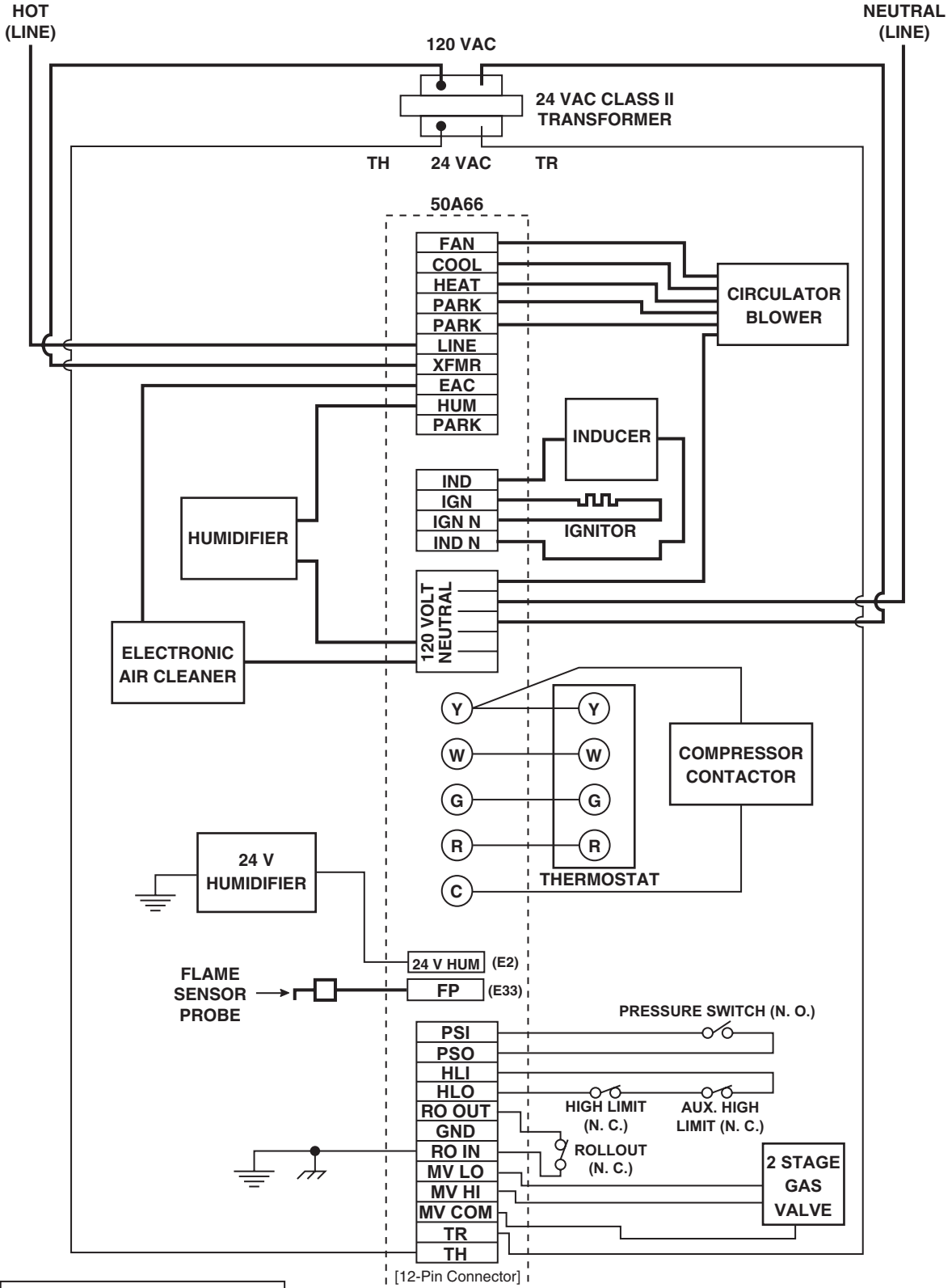

LEGEND	
	Low Voltage (24 VAC)
	Line Voltage (120 VAC)
	N. C. = Normally closed switch
	N. O. = Normally open switch



4-Pin Connector

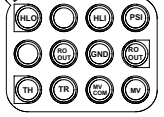

12-Pin Connector

TYPICAL SYSTEM WIRING TABLE

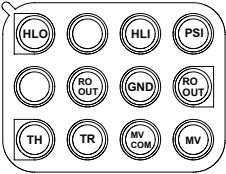
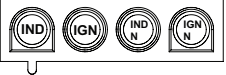
50A66 TERMINAL	TERMINAL TYPE	SYSTEM COMPONENT CONNECTION
W G R Y C	Terminal block with captive screws	low voltage thermostat W terminal (or equivalent) low voltage thermostat G terminal (or equivalent) low voltage thermostat R terminal (or equivalent) low voltage thermostat Y terminal (or equivalent) (2nd wire from Y terminal goes to 24 VAC HOT side of compressor contactor coil) 24 VAC COMMON side of compressor contactor coil
HLO (Pin 1) Not Used (Pin 2) TH (Pin 3) Not Used (Pin 4) RO1 (Pin 5) TR (Pin 6) HLI (Pin 7) GND (Pin 8) MV COM (Pin 9) PSI (Pin 10) RO2 (Pin 11) MV (Pin 12)		high limit OUTPUT 24 VAC transformer (low voltage HIGH side) rollout switch OUTPUT 24 VAC transformer (low voltage COMMON side) high limit INPUT MUST BE RELIABLY GROUNDED TO CHASSIS gas valve COMMON pressure switch INPUT rollout switch INPUT gas valve
IND IGN IND N IGN N		inducer HOT side ignitor HOT side inducer NEUTRAL side ignitor NEUTRAL side
COOL	1/4" spade terminal	circulator blower COOL SPEED terminal
HEAT	1/4" spade terminal	circulator blower HEAT SPEED terminal
PARK (3 terminals)	1/4" spade terminal	unused circulator blower terminals
LINE	1/4" spade terminal	input voltage (120 VAC) HOT side
XFMR	1/4" spade terminal	24 VAC transformer line voltage HOT side
EAC (optional)	1/4" spade terminal	electronic air cleaner HOT side
HUM (optional)	1/4" spade terminal	humidifier HOT side
120 VOLT NEUTRAL (5 terminals)	1/4" spade terminal	Terminals for 120 Volt NEUTRAL for line, transformer, circulator, electronic air cleaner and humidifier
FP (E33)	3/16" spade terminal	flame sensor probe*
FAN	1/4" spade terminal	Circulator blower fan speed terminal
24 V HUM (E2)	1/4" receptacle	24 VAC humidifier

* maximum recommended flame probe wire length is 36 inches.

OPERATION

OPTION SWITCHES

The option switches on the 50A66-743 control are used to determine the length of the heat delay-to-fan-off period. The following table shows the time periods that will result from the various switch positions.

OPTION SWITCH POSITIONS			
HEAT delay-to-fan-off:	Set switch		
	#1	#2	
60 sec.	Off	Off	
90 sec.*	Off	On	
120 sec.	On	Off	
180 sec.	On	On	

COOL delay-to-fan-off:	Set switch	
	#3	
2 sec.	Off	
45 sec.*	On	

* Factory Setting

HEAT MODE

In a typical system, a call for heat is initiated by closing the thermostat contacts. This starts the 50A66 control's heating sequence. The inducer blower and humidifier are energized. After a 15-second prepurge period, the 768A Silicon Nitride ignitor is powered.

This controller has an adaptive algorithm that reduces the ignitor temperature to slightly greater than the minimum temperature required to ignite gas in each particular application. The control measures the line voltage and determines an initial ignitor temperature setting based on the measurement. After each successful ignition, the control lowers the ignitor temperature slightly for the next ignition attempt. The control continues to lower the ignitor temperature until ignition does not occur, and the control goes into retry mode. For the second attempt to ignite gas within the same call for heat, the control increases the ignitor temperature to the value it was on the third previous successful ignition. After ignition is successful, the control sets the ignition temperature at this value for the next 255 calls for heat, after which the control repeats the adaptive algorithm. The control is constantly making adjustments to the ignitor temperature to compensate for changes in the line voltage.

The 80 VAC Silicon Nitride ignitor manufactured by White-Rodgers must be used. These ignitors are specially designed to operate with the 50A66's adaptive ignition routine to ensure the most efficient ignitor temperature.

At the end of the ignitor warm-up time, both valves in the 36E manifold gas valve are opened. Flame must be detected within 4 seconds.

If flame is detected, the delay-to-fan-on period begins. After the delay-to-fan-on period ends, the circulator fan is energized at heat speed. If there is an optional electronic air cleaner on the system, the electronic air cleaner and the humidifier are energized. When the thermostat is

satisfied, the gas valve is de-energized. After proof of flame loss, the inducer blower remains energized to purge the system for 5 seconds and the delay-to-fan-off period begins. When the purge is complete, the inducer blower and humidifier are de-energized. After the delay-to-fan-off period ends, the circulator fan and electronic air cleaner are de-energized.

If flame is not detected, both valves are de-energized, the ignitor is turned off, and the 50A66 control goes into the "retry" sequence. The "retry" sequence provides a 15-second wait following an unsuccessful ignition attempt (flame not detected). After this wait, the ignition sequence is restarted. If this ignition attempt is unsuccessful, three more retries will be made before the control goes into system lockout.

If flame is detected, then lost, the 50A66 control will repeat the initial ignition sequence for a total of three "recycles". After three unsuccessful "recycle" attempts, the control will go into system lockout.

If flame is established for more than 10 seconds after ignition, the 50A66 controller will clear the ignition attempt (or retry) counter. If flame is lost after 10 seconds, it will restart the ignition sequence. This can occur a maximum of four times before system lockout.

A momentary loss of gas supply, flame blowout, or a shorted or open condition in the flame probe circuit will be sensed within 2 seconds. The gas valve will de-energize and the control will restart the ignition sequence. Recycles will begin and the burner will operate normally if the gas supply returns, or the fault condition is corrected, before the last ignition attempt. Otherwise, the control will go into system lockout.

If the control has gone into system lockout, it may be possible to reset the control by a momentary power interruption of ten seconds or longer. Refer to **PRECAUTIONARY, SYSTEM LOCKOUT, AND DIAGNOSTIC FEATURES.**

COOL MODE

In a typical system, a call for cool is initiated by closing the thermostat contacts. This starts the 50A66 control's cooling sequence. The compressor is energized and the delay-to-fan-on period begins. After the delay-to-fan-on period ends, the circulator fan is energized at cool speed. The electronic air cleaner (optional) is also energized. After the thermostat is satisfied, the compressor is de-energized and the delay-to-fan-off period begins. After the delay-to-fan-off period ends, the circulator fan and electronic air cleaner are de-energized.

MANUAL FAN ON MODE

If the thermostat fan switch is moved to the ON position, the circulator fan (heat speed) and optional electronic air cleaner are energized. When the fan switch is returned to the AUTO position, the circulator fan and electronic air cleaner (optional) are de-energized.

SYSTEM LOCKOUT AND DIAGNOSTIC FEATURES

SYSTEM LOCKOUT FEATURES

When system lockout occurs, the gas valve is de-energized. The circulator blower may be energized at heat speed for some faults, and if flame is sensed, the inducer blower is energized. The diagnostic indicator light will flash or glow continuously to indicate system status. **(System lockout will never override the precautionary features.)**

To reset the control after system lockout, do one of the following:

1. Interrupt the call for heat at the thermostat for at least one second, but for less than 20 seconds (if flame is sensed with the gas valve de-energized, interrupting the call for heat at the thermostat will **not** reset the control).

2. Interrupt the 24 VAC power at the control for at least ten seconds. You may also need to reset the flame rollout sensor switch.
3. After one hour in lockout, the control will automatically reset itself.

DIAGNOSTIC FEATURES

The 50A66-743 control continuously monitors its own operation and the operation of the system. If a failure occurs, the DS 1 (red) and DS 2 (green) LEDs will indicate a failure code as shown below.

TROUBLESHOOTING

DIAGNOSTIC TABLE

DS 1 (Red)	DS 2 (Green)	Error/Condition	Comments/Troubleshooting
Simultaneous slow flash	Simultaneous slow flash	Normal operation	No fault
Simultaneous fast flash	Simultaneous fast flash	Normal operation with call for heat	Normal operation
Slow flash	On	Open limit switch	Verify continuity through rollout switch circuit
Off	Slow flash	Pressure switch stuck closed/open	Pressure switch stuck closed. Check switch function, verify inducer is turning off. Pressure switch stuck open. Check pressure switch function and tubing. Verify inducer is turning on and pulling sufficient vacuum to engage switch.
Alternate slow flash	Alternate slow flash	External lockout (retries)	Failure to sense flame is often caused by carbon deposits on the flame sensor, a disconnected or shorted flame sensor lead or a poorly grounded furnace. Carbon deposits can be cleaned with emery cloth. Verify sensor is not contacting the burner and is located in a good position to sense flame. Ignitor must be positioned to light the gas immediately when the valve opens. If the ignitor has been replaced, verify hot spot position has not changed. Check sensor lead for shorting and verify furnace is grounded properly.
Slow flash	Off	Flame sensed with gas valve de-energized	Verify the gas is operating and shutting down properly. Flame in burner assembly should extinguish promptly at the end of the cycle. Check orifices and gas pressure.
On	Slow flash	Open rollout switch	Verify continuity through rollout switch circuit.
On	On	Module – internal fault condition	Module contacts for gas valve not operating or processor fault. Reset control, if condition persists, replace module.
Slow flash	Fast flash	Low flame sense current	Low flame sense current is often caused by carbon deposits on the flame sensor, a poorly grounded furnace or a mis-aligned flame sense probe. Carbon deposits can be cleaned with emery cloth. Check or improve furnace and module ground. Verify sensor is located in or very near flame as specified by the appliance manufacturer.
Fast flash	Slow flash	Grounding or reversed polarity	Verify the control and furnace are properly grounded. Check and reverse polarity (primary) if incorrect.
Alternate fast flash	Alternate fast flash	Module ignitor contact failure	Fault code indicates the module ignitor contacts are not functioning properly. Replace module.

HOMEOWNER HELP LINE: 1-800-284-2925

White-Rodgers is a business of Emerson Electric Co.

The Emerson logo is a trademark and service mark of Emerson Electric Co.

White
Rodgers™

www.white-rodgers.com
www.emersonclimate.com

EMERSON™
Climate Technologies